



Power Take Offs

Relation 1 : 1,73

Ref. TF8021AMP

MERCEDES

G-60 ; G-85 REINFORCED

To apply with Gear Pumps or with Piston Pumps

Main Dimensions

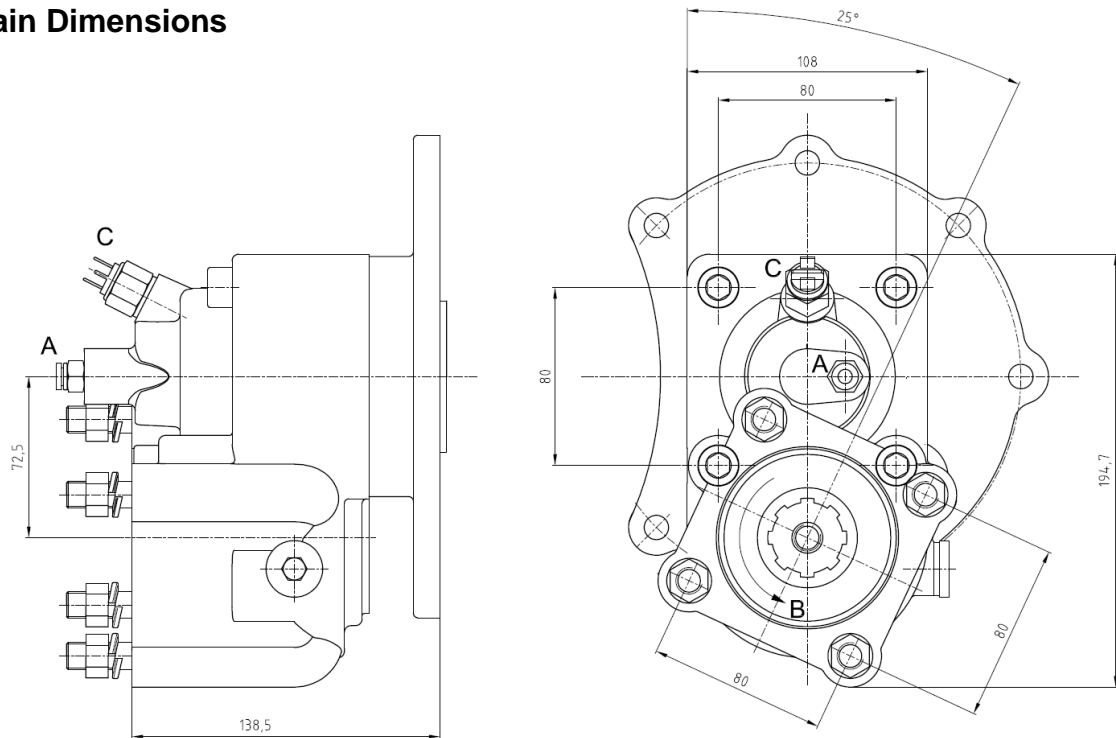

A – Air connection

B – Pump rotation

C – Option: Electric sensor with mechanical driving Ref. TF8021AMPS or TF8021AMPC

(Dimensions in mm)

Main Data

Continuous Torque (Nm)	350
Intermittent Torque (Nm)	450
Power (at 1000 rpm)	48 cv / 36 kW
Mounting Position	Rear
Pump Rotation	Right Hand
Weight (kg)	14.2
PTO internal ratio	1:1,73
Indicative ratio from motor to PTO's output	
G60 - 6/ 9.2	- 1 : 0.950
G85 - 6/ 6.7	- 1 : 1.074