

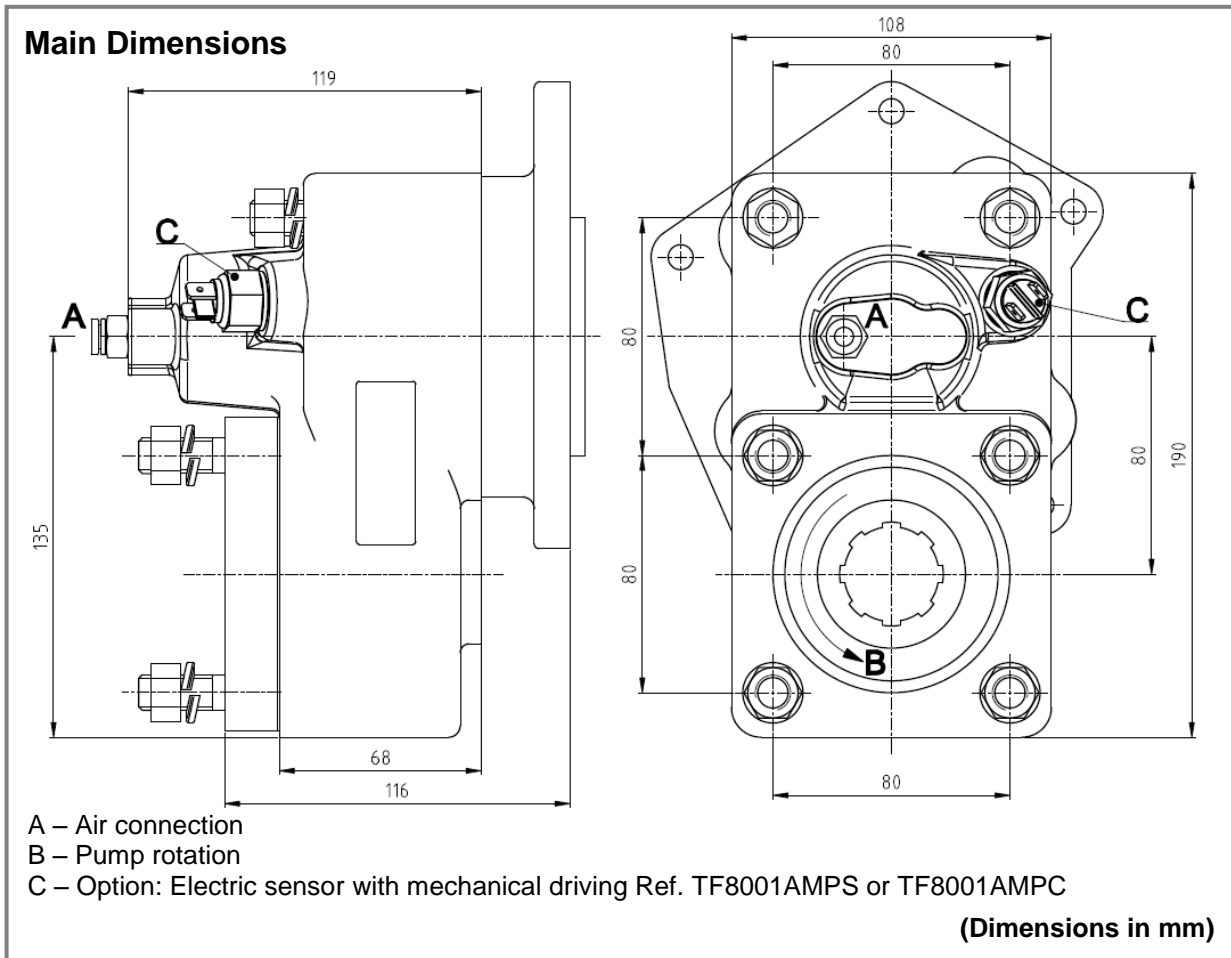

Power Take Offs Relation 1 : 1,32		Ref. TF8001AMP
MERCEDES	G3/36 ; G3/40 ; G3/45 ; G3/50 ; G3/55 ; G3/60 ; G3/61	

To apply with Gear Pumps or with Piston Pumps



Main Data			
Continuous Torque (Nm)			300
Intermittent Torque (Nm)			420
Power (at 1000 rpm)			42 cv / 32 kW
Mounting Position			Rear
Pump Rotation			Right Hand
Weight (kg)			10
PTO internal ratio			1:1,32
Indicative ratio from motor to PTO's output			
G3/40 - 5/ 7.508	- 1 : 0.622	G3/60 - 5/ 6.106	- 1 : 0.768
G3/45 - 6/ 8.5	- 1 : 0.606	G3/60 - 5/ 7.5	- 1 : 0.622
G3/50 - 5/ 8.5	- 1 : 0.555	G3/61 - 5/ 6.1	- 1 : 0.763
G3/55 - 6/ 8.5	- 1 : 0.606	G3/36 - 5/ 8.98	- 1 : 0.521
G3/60 - 5/ 5.4	- 1 : 0.861		

ABER is constantly engaged in improving its products and, therefore, reserves itself the right to modify without any further notice the characteristics shown. The gear boxes are in constant change; therefore, ABER is not to be held responsible for any damage resulting from wrong application or application of outdated material.



ABER - Embraiaçes e Comandos Hidráulicos - A. B. LDA
 Rua Francisco de Almeida, Nº 30 – Vila Nova da Telha – 4470 MAIA - Portugal
 Telephone: +351.22.9438070 Fax: +351.22.9420823 e-mail: aber@aber.pt <http://www.aber.pt>