



Power Take Offs

Relation 1 : 1,56

Ref. TF7011AMP

EATON

FS 5109 ; FSO 5109 ; FS 6109 ; FSO 6109
FS 8209 ; FSO 8209 ; FS 8309 ; FSO 8309

To apply with Gear Pumps or with Piston Pumps

Main Dimensions

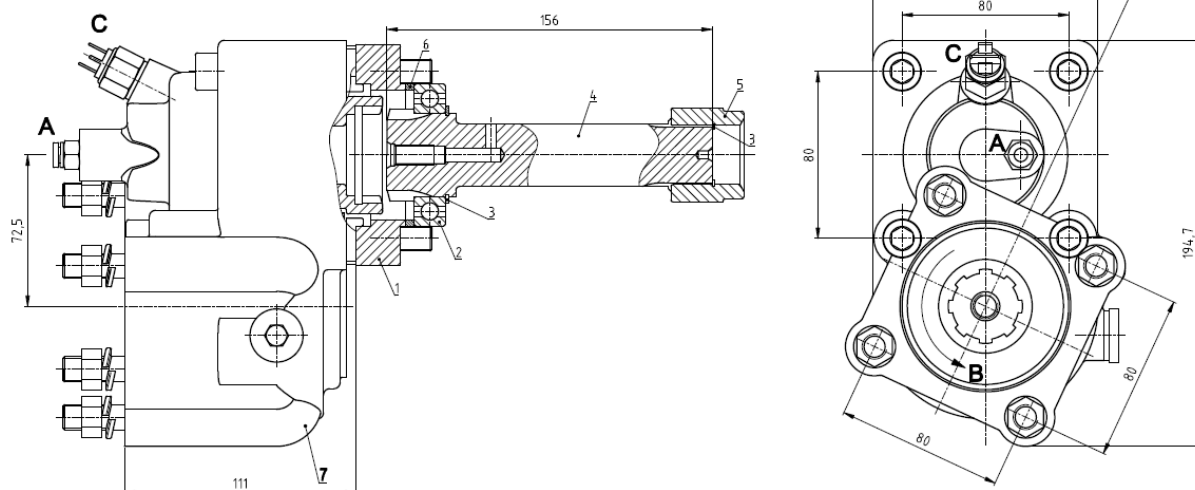

A – Air connection

B – Sense of rotation

C – Option: Electric sensor with mechanical driving Ref. TF7011AMPS or TF7011AMPC

1 – Flange

2 – Bearing

3 – Circlip

4 – Adapter shaft VK7002

5 – Adapter sleeve

6 – Adapter washer

7 – TF4035AMP

(Dimensions in mm)

Main Data

Continuous Torque (Nm)	400
Intermittent Torque (Nm)	500
Power (at 1000 r.p.m)	55 C.V. / 40 Kw
Mounting Position	Rear
Pump Rotation	Right Hand
Weight (Kg)	13.5
PTO internal ratio	1:1,56
Indicative ratio from motor to PTO's output	
5109 DT - 1 : 1.106	FS 8209 A - 1 : 1.276
5109 OD - 1 : 1.462	FSO 8209 A - 1 : 1.276
6109 DT - 1 : 1.194	FS 8309 A - 1 : 1.276
6109 OD - 1 : 1.598	FSO 8309 A - 1 : 1.276