



POWER TAKE OFFS

Ref. TF4030P

ZF

6S-300 ; 6S-350 Pneumatic Control

To apply with Gear Pumps or Piston Pumps

Main Dimensions

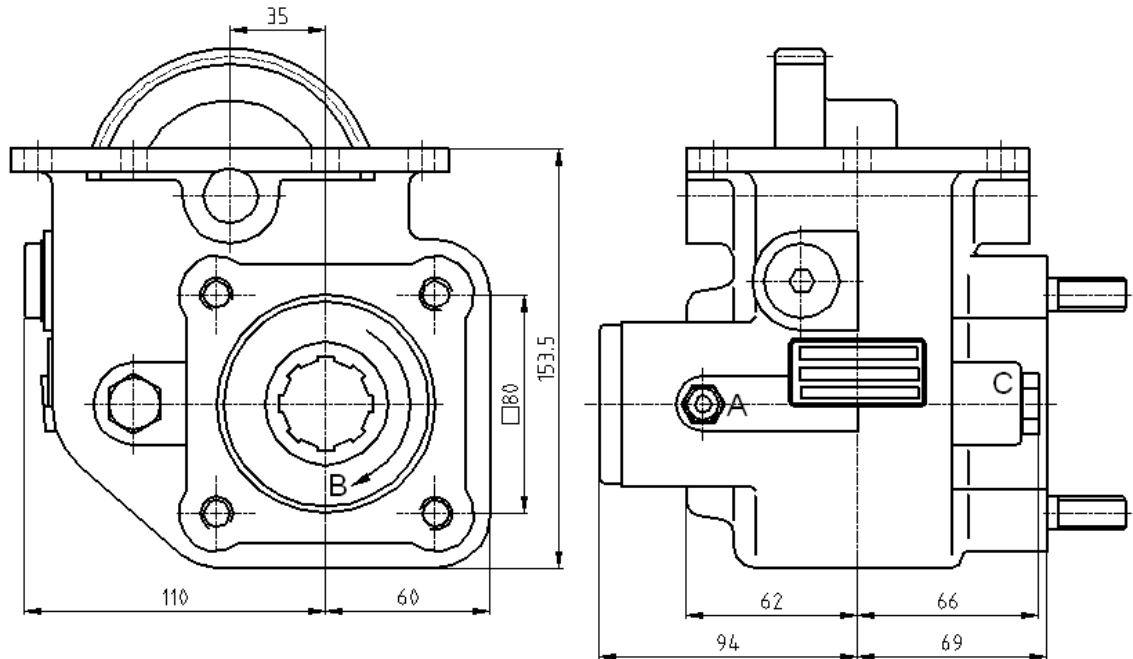

A – Pneumatic connection

B – Pump rotation

C – Option: Electric sensor with mechanical driving Ref. TF4030PS or TF4030PC

(Dimensions in mm)

Main Data

Continuous Torque (Nm)	300
Intermittent Torque (Nm)	420
Power (at 1000 rpm)	42 cv / 32 kW
Mounting Position	Left
Pump Rotation	Left Hand
Weight (Kg)	12
PTO internal ratio	1.1,58
Indicative ratio from motor to PTO's output	1:1,05