



POWER TAKE OFFS

Ref. TF4029V

ZF

5S-200 ; 5S-300 ; 2830.5 Vacuum Control

To apply with Gear Pumps or Piston Pumps

Main Dimensions

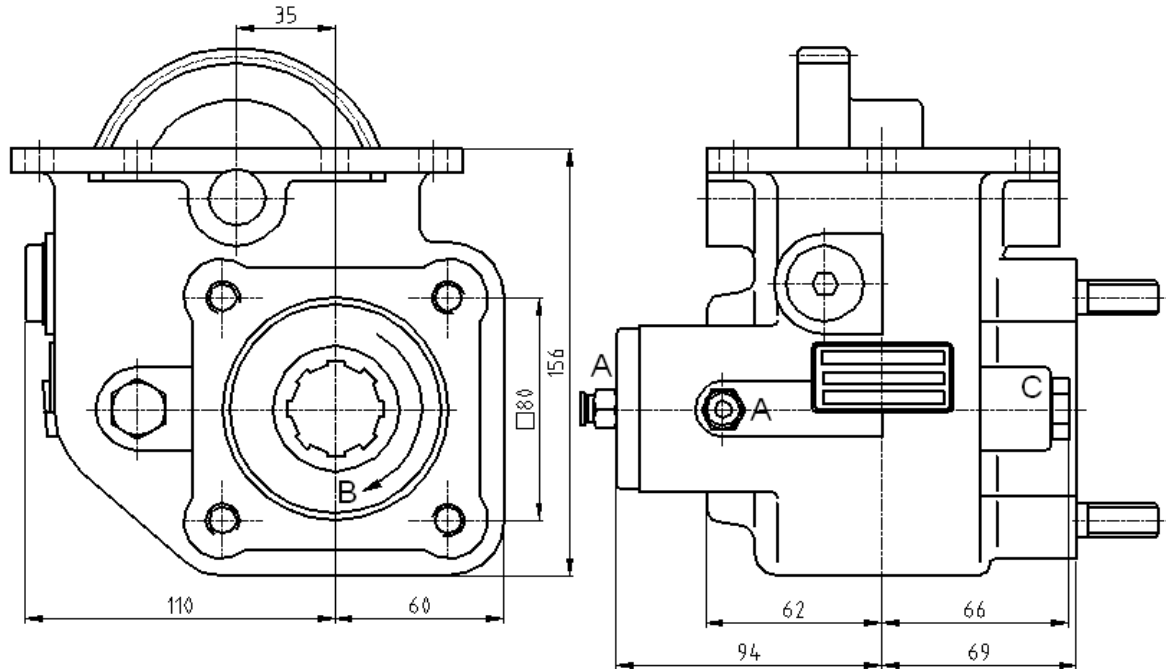

A – Vacuum connection

B – Pump rotation

C – Option: Electric sensor with mechanical driving Ref. TF4029VS or TF4029VC

(Dimensions in mm)

Main Data

Continuous Torque (Nm)	300
Intermittent Torque (Nm)	420
Power (at 1000 rpm)	42 cv / 32 kW
Mounting Position	Left
Pump Rotation	Left Hand
Weight (kg)	12
PTO internal ratio	1:1,65
Indicative ratio from motor to PTO's output	1:1,24