



Power Take Offs

Ref. TF3012M

ISUZU

MBP 6R Mechanic Control

Main Dimensions

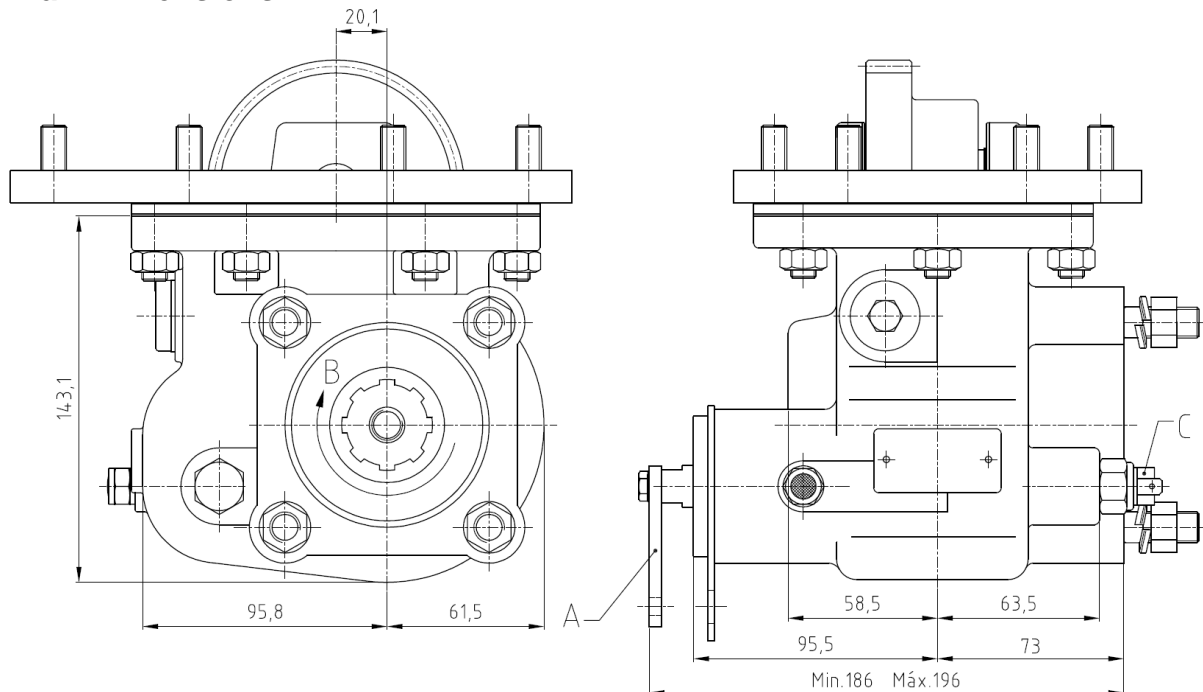

A – Mechanic control

B – Pump rotation

C – Option: Electric sensor with mechanical driving Ref.TF3012MS or TF3012MC

(Dimensions in mm)

Main Data

Continuous Torque (Nm)	300
Intermittent Torque (Nm)	420
Power (at 1000 r.p.m)	42 C.V. / 32 Kw
Mounting Position	Left
Pump Rotation	Left Hand
Weight (Kg)	14.3
PTO internal ratio	1:1,13
Indicative ratio from motor to PTO's output	