



Power Take Offs

Relation 1 : 1,35

Ref. TF11002P

IVECO

2865.6

Main Dimensions

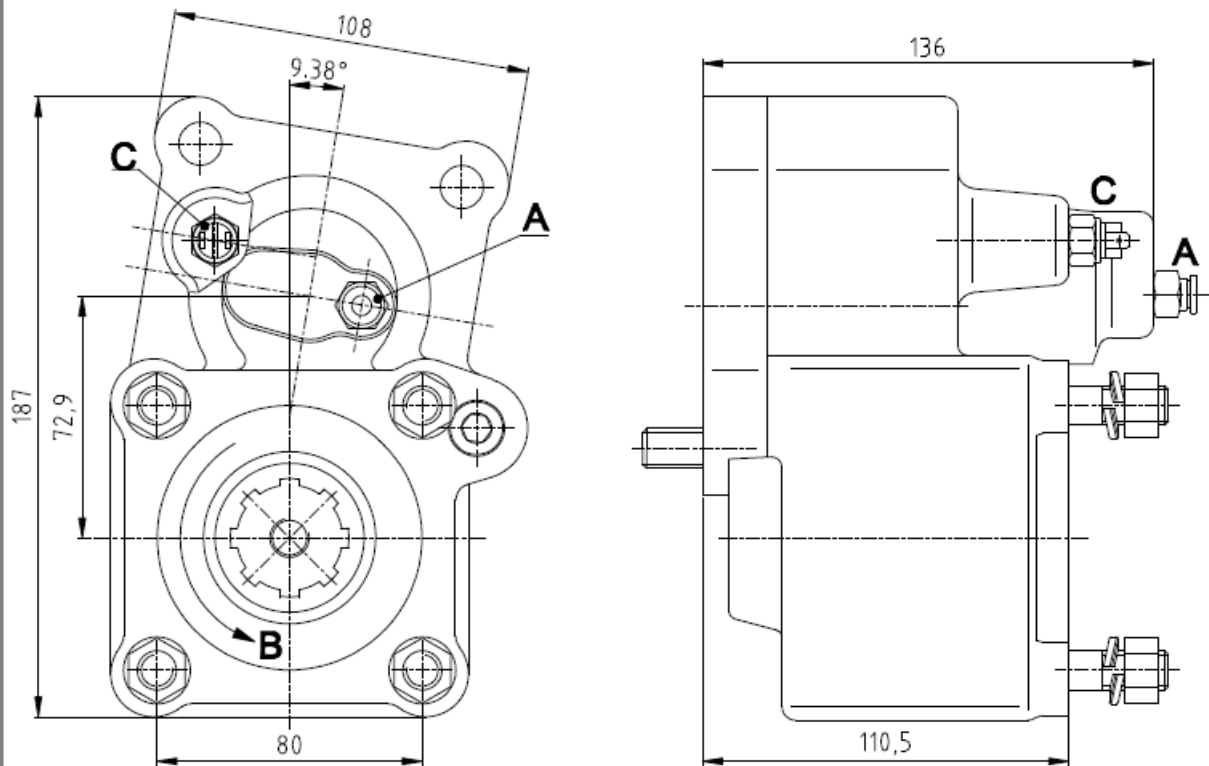

A – Air connection

B – Pump rotation

C – Option: Electric sensor with mechanical driving Ref. TF11002PS or TF11002PC

(Dimensions in mm)

Main Data

Continuous Torque (Nm)	300
Intermittent Torque (Nm)	420
Power (at 1000 rpm)	42 cv / 32 kW
Mounting Position	Rear
Pump Rotation	Right Hand
Weight (kg)	10
PTO internal ratio	1:1,350
Indicative ratio from motor to PTO's output	1:0,579