



Power Take Offs

Ref. TF10012P

SCANIA

GRS905 ; 1200Nm ; Shaft 524 mm

Main Dimensions

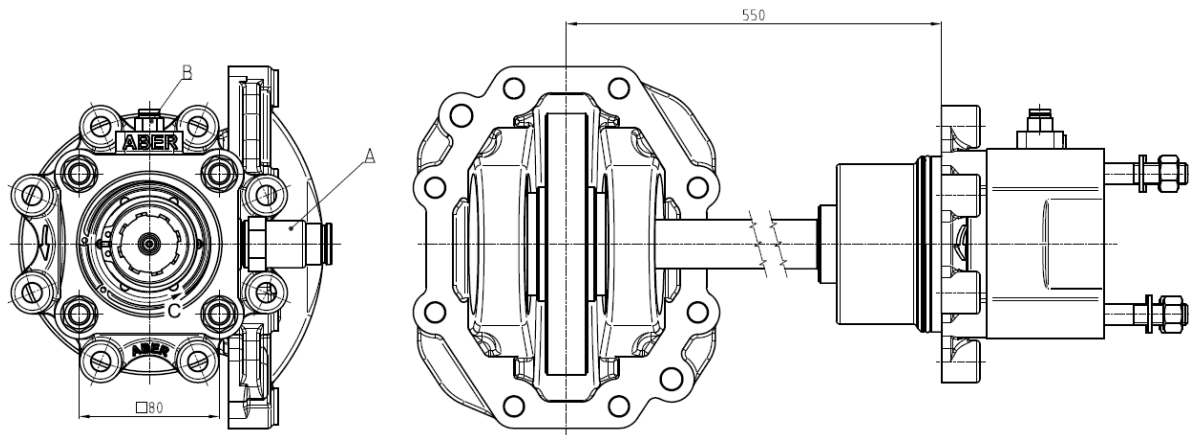

- A – Option: Electric sensor with mechanical driving Ref. TF10012PS or TF10012PC
 B – Air connection
 C – Pump rotation

(Dimensions in mm)

Main Data

Continuous Torque (Nm)	400
Intermittent Torque (Nm)	550
Power (at 1000 rpm)	56 cv / 41 kW
Mounting Position	Right
Pump Rotation	Right Hand
Weight (kg)	22
PTO internal ratio	1:1
Indicative ratio from motor to PTO's output	1:1,24